

Towbar accessories:

Pos. 1 Name: Main bar Quantity: 1	Pos. 5 Name: Left bracket Quantity: 1	Pos. 10 Name: Nut 8 B Quantity: 2 Dim.: M12	Pos. 15 Name: Spring washer Quantity: 6 Dim.: ϕ 10,2 mm
Pos. 2 Name: Tow ball Quantity: 1	Pos. 6 Name: Right jib with the nut Quantity: 1	Pos. 11 Name: Nut 8 B Quantity: 4 Dim.: M10	Pos. 16 Name: Bolt 8,8 B Quantity: 1 Dim.: M8x45mm
Pos. 3 Name: Socket plate Quantity: 1	Pos. 7 Name: Left jib with the nut Quantity: 1	Pos. 12 Name: Plain washer Quantity: 2 Dim.: ϕ 13 mm	Pos. 17 Name: Plain washer Quantity: 2 Dim.: ϕ 8,5 mm
Pos. 4 Name: Right bracket Quantity: 1	Pos. 8 Name: Bolt 8,8 B Quantity: 2 Dim.: M12x70mm	Pos. 13 Name: Plain washer Quantity: 8 Dim.: ϕ 10,5 mm	Pos. 18 Name: Nut 8 B Quantity: 1 Dim.: M8
	Pos. 9 Name: Bolt 8,8 B Quantity: 4 Dim.: M10x40mm	Pos. 14 Name: Spring washer Quantity: 2 Dim.: ϕ 12,2 mm	Pos. 19 Name: Spring Quantity: 1
			Pos. 20 Name: Ball cover Quantity: 1



Produkcja Zaczepów Kulowych
Henryk & Zbigniew Nejman
76-200 SŁUPSK ul. Słoneczna 16K
tel/fax (059) 8-414-414; 8-414-413
E-mail: office@autohak.com.pl
www.autohak.com.pl

Towing hitch (without electrical set)

Class: **A50-X** Cat. no. **R38**

Designed for:

Manufacturer: **FIAT**

Model: **GRANDE PUNTO**

produced since 10.2005

Technical data:

D-value: 7,03 kN

maximum trailer weight: **1200 kg**

maximum vertical cup load: **60 kg**

Approval number according to Directive 94/20/EC: e20*94/20*1352*00

Foreword

This towbar is designed according to rules of safety traffic regulations. The towing hitch is a safety component and can be install only by qualified personnel. Any alteration or conversion of the towing hitch is prohibited and would lead to cancellation of design certification. Remove insulating compound and underseal from vehicle (if present) in the area of the matting surfaces of the towing hitch.

The vehicle manufacturer's specifications regarding trailer load and max. vertical cup load are decisive for driving whereat values for the towing hitch cannot be exceeded.

D-value formula:

$$\frac{\text{Max trailer weight [kg]} \times \text{Max vehicle weight [kg]}}{\text{Max trailer weight [kg]} + \text{Max vehicle weight [kg]}} \times \frac{9,81}{1000} = D \text{ [kN]}$$

FITTING INSTRUCTION

Clamp mark in acc. with		Cables joining
ISO	PN	
1	L	Left directional lights
2	+	Rear fog lights
3	31	Ground
4	R	Right directional lights
5	58R	Right side parking lights
6	54	Stoplights
7	58L	Left side parking lights

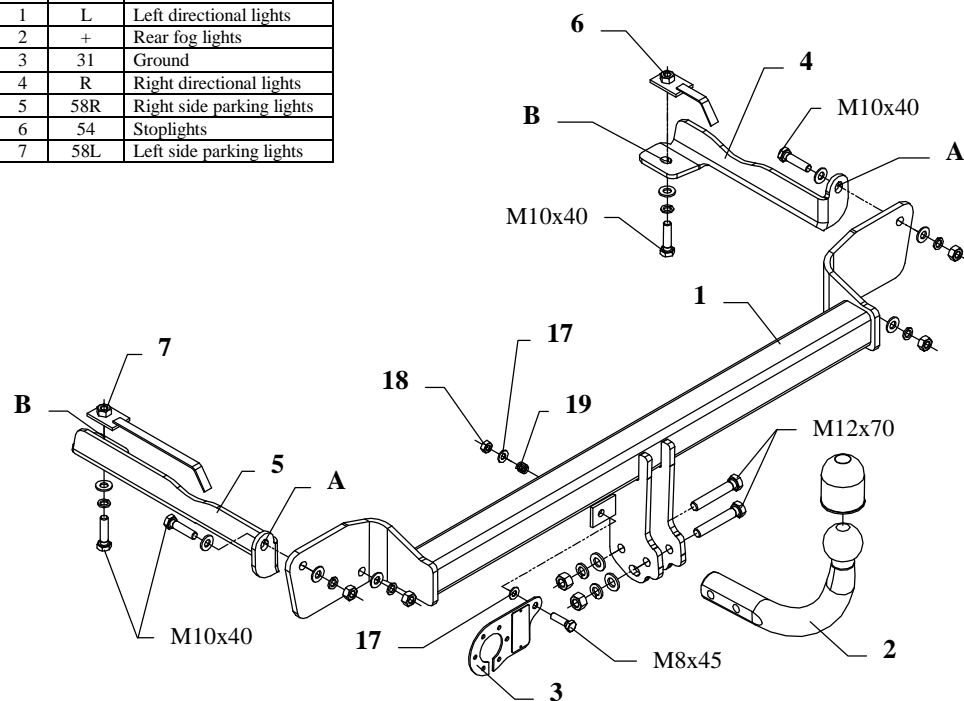

Fig. 1

This towbar is designed to assembly in following cars:
FIAT GRANDE PUNTO, produced since 10.2005, catalogue no. **R38** and is prepared to tow trailers max total weight **1200 kg** and max vertical load **60 kg**.

From manufacturer

Thank you for buying our product. Their reliability has been confirmed in many tests. Reliability of towbar depends also on correct assembly and right operation. For this reasons we kindly ask to read carefully this instruction and apply to hints.

The towbar should be install in points described by a car producer.

The instruction of the assembly

1. Unscrew the bumper.
2. Lower the muffler from back handle.
3. Unscrew the metal reinforcement of the bumper (will not be assembled again).
4. Apply the main bar of the towbar (pos. 1) on the protruding bolt M10 in place of unscrewing reinforcement and fix it loosely.
5. Apply brackets of the towbar (pos. 4 and 5) to chassis into such way so holes (pos. A and B) be covered with holes in the back piece and with holes in the chassis member.
 - holes (pos. A) fix with the main bar of the towbar (pos. 1) using bolts M10x40mm (pos. 9),
 - holes (pos. B) fix to the chassis member using bolts M10x40mm (pos. 9) – use jibs with the nuts (pos. 6 and 7), which one ought to put through holes in chassis members.
6. Hang up the muffler.
7. Install the bumper after cut out of its fragment (see fig. 2).

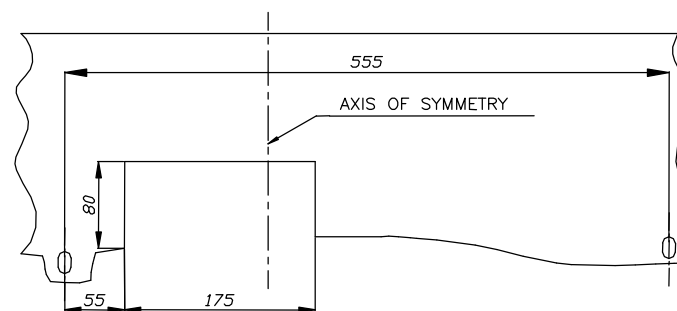

Fig. 2

8. Fix tow-ball (pos. 2) using bolts M12x70mm (pos. 8) from accessories.
9. Fix the socket plate (pos. 3) as shown on the drawing.
10. Tighten all bolts according to the torque shown in the table.
11. Connect electric wires of 7-poles socket according to the instruction of the car. (Recommend to make at authorized service station).
12. Complete paint layer damaged during installation.

Torque settings for nuts and bolts (8,8):

M6 - 11 Nm	M8 - 25 Nm	M10 - 50 Nm
M12 - 87 Nm	M14 - 138 Nm	M16 - 210 Nm

NOTE

After install the towbar you should get adequate note in registration book (at authorised service station).The car should be equipped with:

- Indicators
- Tow mirrors

After 1000km of exploitation check all bolts and nuts. The ball of towbar must be always kept clear and conserve with a grease.